



BOLT-A-PLATE®
Structural Steel Plate

ail.ca



BUILD IN VALUE WITH BOLT-A-PLATE® STRUCTURAL STEEL PLATE.

NET ZERO BY
2050 ✓



Atlantic Industries Limited
We Support You.

- 2 About Bolt-A-Plate®
- 4 Features & Benefits
- 6 Applications Gallery
- 10 Geometries & Specifications

- 14 Installation
- 15 Options
- 16 Structural Plate Bridges & Tunnels



Active Transportation Underpass, Calgary, Alberta

TAKE A 360°
VIDEO TOUR



We've been adding value to some of the world's most successful infrastructure projects for over 60 years.

Easy to ship and install in remote locations



Shipping Components for Klondike Highway Project, Ayr, Ontario

Some smaller structures can be shipped assembled

We're all about support.

Engineered structures from Atlantic Industries Limited (AIL) can support multiple lanes of highway traffic, the heaviest freight trains or the largest mining vehicles. However, those structures are only as strong as the people supporting them with full design and engineering services, on-time manufacturing and delivery and dependable field supervision. Our people have been supporting some of the world's largest infrastructure projects for over 60 years.

A Canada-wide network and international scope

With a Canada-wide network of sales teams, engineering offices and manufacturing facilities, AIL is a proven project partner ready to help you through every stage of your next infrastructure project. Plus, as a member of The AIL Group of Companies, we bring a world of resources and expertise to our projects in the transportation, public works, mining, development and forestry sectors.

AIL offers a wide range of efficient bridges — Structural Plate, Prefabricated, Modular — all engineered to deliver optimum performance and value for your application. We also provide supporting products like Corrugated Pipe, MSE Retaining Walls, Abutment Systems and Sound Barrier Walls. By design, our complete line of resilient and sustainable solutions are easy to ship and install with minimal equipment and labour requirements, making them ideal even in remote locations.



For project assistance throughout Canada, call 1-877-245-7473.
Outside Canada, call +1-778-335-7000.

RECOMMENDED FOR

- ▶ Bridges and Tunnels
- ▶ Conveyor Covers and Overcasts
- ▶ Culvert Relines
- ▶ Fish Passages
- ▶ Grade Separations
- ▶ Heavy Haul Road Crossings
- ▶ Portals and Canopies
- ▶ Road or Rail Underpasses
- ▶ Stockpile and Escape Tunnels
- ▶ Storage Structures
- ▶ Stream Crossings
- ▶ Underground Structures
- ▶ Utilidor Systems
- ▶ Vertical Shafts and Vent Raises



This Bolt-A-Plate® recreational trail and wildlife underpass installed in just eight days. Highway 97, British Columbia.



TAKE A 360° VIDEO TOUR

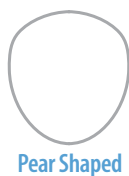
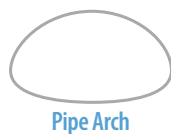
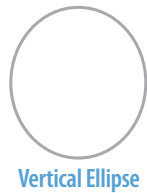
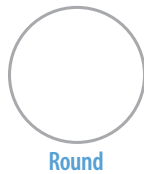

BOLT-A-PLATE®
Structural Steel Plate

Recommended for smaller applications.

For a strong, effective bridging alternative, Bolt-A-Plate® is the product of choice for its light weight, strength and versatility. Bolt-A-Plate® is available in a wide variety of shapes and sizes.

It is perfect for highly economical Buried Metal Bridge and drainage structure construction or replacement, as well as many other applications in the transportation, public works, mining and forestry sectors.

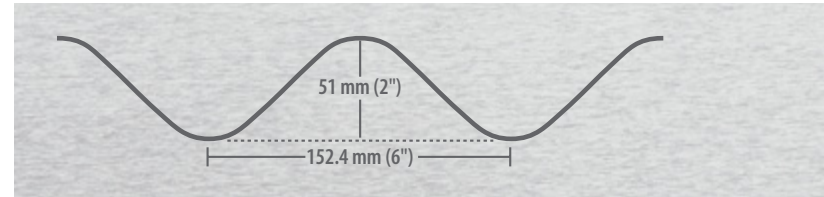

- ▶ Industry-standard, hot-dip-galvanized, corrugated structural steel plate for smaller applications
- ▶ Spans of 1.5 m (5') to 10 m (33')
- ▶ Corrugation profile of 152.4 mm (6") pitch × 51 mm (2") depth
- ▶ Bottomless designs maintain natural streambeds
- ▶ Can reline older structures
- ▶ Available with tested and approved protective coating systems
- ▶ Designed and manufactured to National Standards at our third-party quality-certified facility ISO 9001-2015



Flood Plain Culverts, Highway 19 Connector, Courtenay, British Columbia



TAKE A 360°
VIDEO TOUR

Corrugated metal structures ship and assemble easily in all seasons and in remote locations, often without the need for concrete.



River Crossing, Hays County, Texas



Premium coatings to extend the service life of structures in aggressive environments.

Building on the years of proven performance of polymer-coated corrugated steel pipe, AIL has partnered with some of the world's leading developers of coatings to provide Best•Kote® Structural Plate Coating. For extended service life of Bolt-A-Plate® structures, Best•Kote® offers superior protection and long-term durability.

- ▶ +75 YEAR service life
- ▶ Economical solution for extended service life of structure; ideal for aggressive environmental conditions
- ▶ Protects against corrosion, abrasion and inorganic acid, salts or alkali (diluted)
- ▶ Can be applied to all or part of a structure
- ▶ Special bolts and fasteners maintain integrity of coating during assembly



Best•Kote® offers long-lasting 360° protection against corrosion, abrasion and inorganic acid, salts or alkali (diluted).

Polymer System

This coating system provides two layers of protection — a zinc-rich base layer and a Polymer finish layer on top of the steel plate.

Polymer Finish Layer

Ethylene Acrylic Acid Polymer provides superior resistance to corrosion, abrasion and inorganic acid, salts or alkali (diluted).

Zinc-Rich Base Layer

Provides excellent corrosion resistance and barrier protection.

Steel Plate

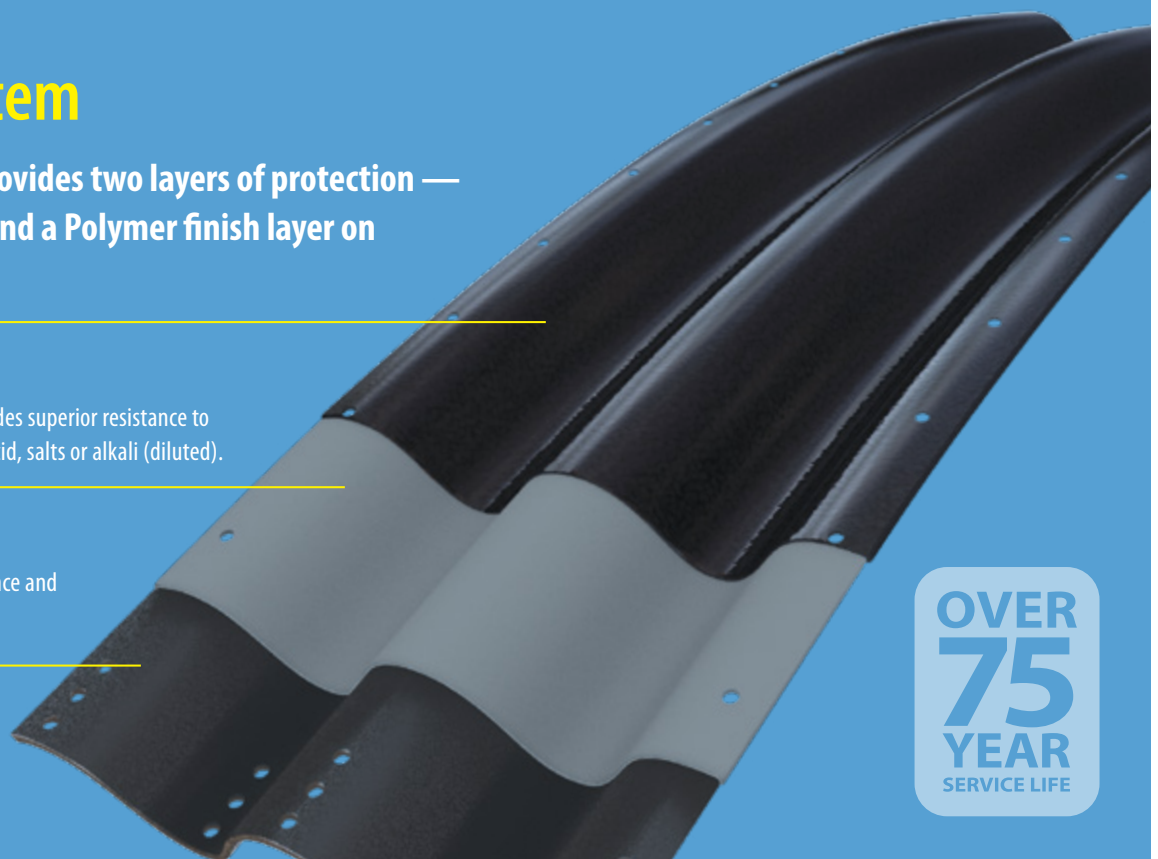

All's Buried Metal Bridges offer many advantages over concrete structures and girder-style bridges.

- ▶ Save time and money on all aspects of the structure: material, shipping, foundations and footings, labour and equipment and life cycle maintenance
- ▶ “Greener” alternatives to concrete structures
- ▶ Seamless, wider and safer road surface than girder-style bridges
- ▶ More flexible and resilient to climate change weather events than concrete structures
- ▶ Minimized site impact
- ▶ Ideal for Accelerated Bridge Construction
- ▶ Customized geometries to meet site-specific requirements
- ▶ Lightweight, easy to ship and install
- ▶ Larger, stronger for the heaviest loads
- ▶ Can accept a range of backfill materials
- ▶ A proven technology with global acceptance
- ▶ Value Engineering opportunities
- ▶ Equally suitable for urban, rural and remote locations



VIEW ALL BURIED METAL BRIDGE BENEFITS



Buried Steel Bridges have a substantially lower life cycle carbon footprint than concrete bridges.

- ▶ Steel is the world's most recycled material*
- ▶ Less energy is used in the production and shipping of Buried Steel Bridges than concrete bridges
- ▶ Buried Steel Bridges can be built in significantly less time, reducing disruption time and detours and expediting construction schedules
- ▶ Buried Steel Bridges require less maintenance than concrete beam bridges
- ▶ Zinc used in galvanizing is a naturally occurring material and is 100% recyclable**

*Reference: www.aisc.org

**Reference: <https://galvanizeit.org/hot-dip-galvanizing/is-galvanizing-sustainable/hdg-environmental-advantages>

We design our Buried Metal Bridges to be resilient to the extreme weather events of climate change.



TAKE A VIDEO TOUR TO LEARN MORE



Transportation - Dawson, Ontario



Public Works - Mission, British Columbia



Private Development - Australia

Strong

The annular corrugations allow Bolt-A-Plate® structures to withstand heavy loads.

Versatile

Long spans, shallow covers, a variety of shapes and reinforcement options extend Bolt-A-Plate's application range.

Durable

Heavy-duty galvanized coating is bonded to surface. Optional Best-Kote™ Polymer Coating can extend service life to over 75 years.



Mining & Energy - Stockpile Tunnel, Nevada



Active Transportation - Calgary, Alberta



Private Development - Custom End Treatment, Texas



Forestry - Integrated Footings



Culvert Reline - Compton, Quebec

Economical

Bolt-A-Plate® is easy to ship and install with local crews and equipment, even in remote locations.

Low Maintenance

Unlike conventional structures, which frequently require retrofits, Bolt-A-Plate® is relatively maintenance-free.

Environmentally Friendly

Made from recycled and recyclable steel, Bolt-A-Plate® structures typically install with less impact on stream beds and fish habitat.



Mining & Energy - Vent Raise, Nunavik



Northern - Watson Lake, Yukon Territory



Mining & Energy - Stockpile Tunnels, Lisbon Valley, Utah



Public Works - Stream Crossing, Ste. Veronique, Quebec



Transportation - Culvert Reline, Saint-Narcisse, Quebec



Built-in resilience to washouts

Forestry - Stream Crossing, Willamette Valley, Oregon



Mining & Energy - Portal, Tumbler Ridge, British Columbia

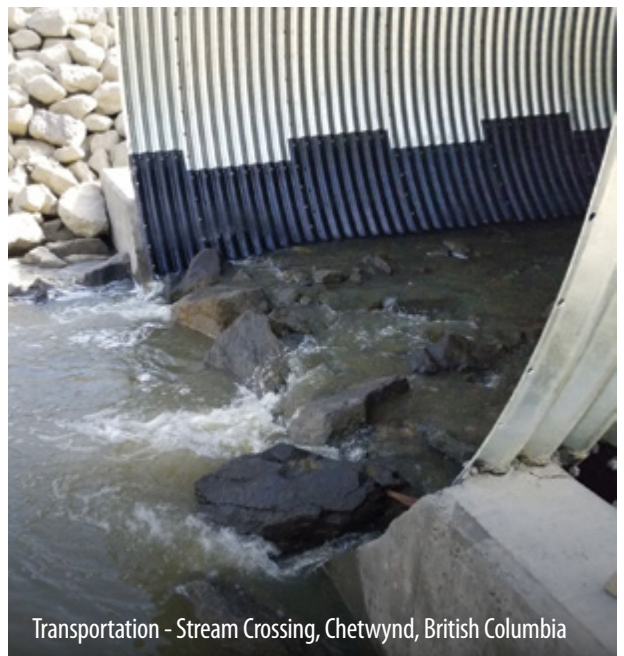

Transportation - Stream Crossing, Chetwynd, British Columbia

Hats off to Bolt-A-Plate® for design versatility in an extended application range.

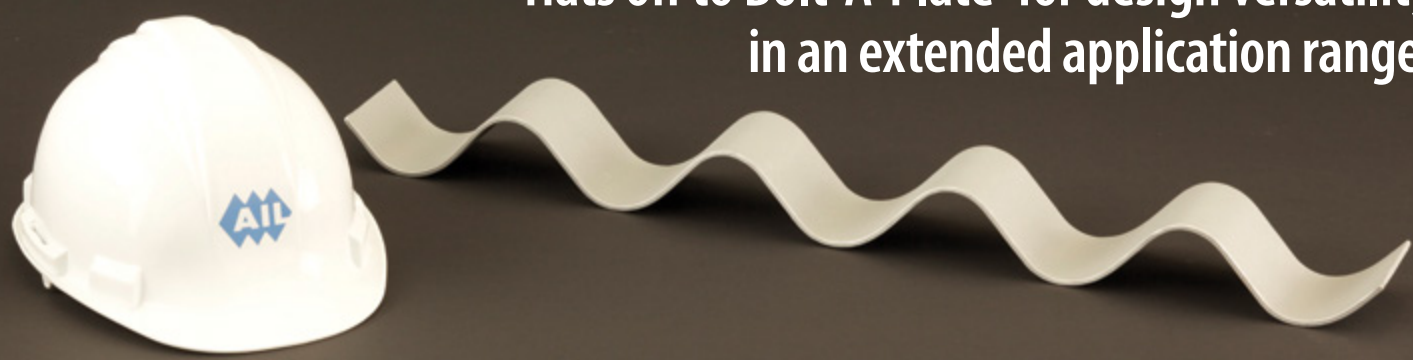

Structure for Commemorative Retaining Wall, Okotoks, Alberta



Park Fire Pit Enclosure, Charlottetown, Prince Edward Island



Bridge Piers, Waegamow Lake, Northern Ontario



Bridge Abutment Backwalls, Laird Highway, Northwest Territories



Headwalls, Klondike Highway 2, Yukon Territory

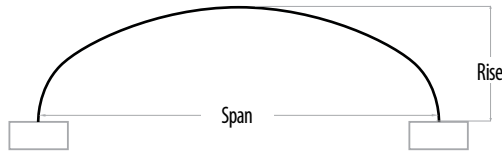

LOW PROFILE ARCH

Low Profile Arches are good choices when there are low cover height restrictions with the need to optimize the natural width and hydraulic flow of stream beds.

No.	Max. Span (mm)	Bottom Span (mm)	Total Rise (mm)	Min. Cover CL-Vehicle (mm)
23LA6	6120	6050	2290	1273
23LA5	5920	5820	2080	1277
25LA6	6550	6500	2360	1390
26LA6	6780	6730	2410	1442
27LA6	7010	6930	2440	1498
28LA6	7240	7160	2490	1561
29LA6	7470	7390	2540	1612
30LA6	7670	7620	2570	1676
31LA6	7900	7850	2620	1731
31LA9	8310	8150	3280	1711
33LA7	8560	8510	2920	1833
33LA9	8760	8610	3350	1827
34LA7	8790	8740	2950	1891
36LA7	9220	9170	3020	2008
36LA9	9420	9270	3480	1999
36LA10	9630	9500	3680	1995
37LA7	9450	9400	3070	2062
37LA10	9860	9730	3730	2044
38LA7	9680	9630	3120	2120
38LA10	10080	9930	3780	2099
39LA9	10110	9960	3610	2166
39LA11	10490	10390	4040	2150
41LA9	10540	10410	3680	2284
41LA14	11560	11460	4780	2262
42LA9	10770	10570	3730	2340
42LA14	11790	11680	4800	2317

ALL DIMENSIONS ARE TO INSIDE CREST OF STEEL
MINIMUM COVER IS FROM NEUTRAL AXIS OF STEEL

CL Vehicle Minimum Cover
CHBDC for Span > 3000 mm
ASTM A796 (AISI) for Span < 3000 mm

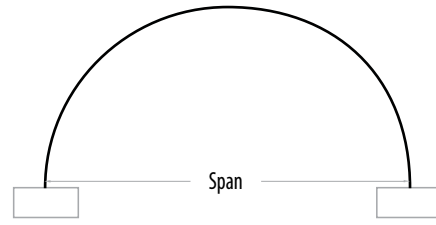

STANDARD ARCH

Standard Arches are recommended for overpasses and watercourse crossings where clearance boxes and end areas are less of a concern.

No.	Max. Span (mm)	Total Rise (mm)	End Area (m ²)	Min. Cover CL-Vehicle (mm)
10A	1520	810	0.98	300
11A	1830	840	300	300
12A1	1830	970	1.39	300
12A2	2130	860	1.39	300
14A1	2130	1120	1.86	300
14A2	2440	1020	1.86	311
16A1	2440	1270	2.42	311
16A2	2740	1180	2.46	349
18A1	2740	1440	3.07	349
18A2	3050	1350	3.16	600
20A	3050	1600	3.81	600
19A	3350	1360	3.44	600
22A	3350	1750	4.65	600
21A	3660	1520	4.18	625
24A	3660	1910	5.48	619
23A	3960	1680	5.02	679
26A1	3960	2060	6.5	669
25A	4270	1840	5.95	729
28A1	4270	2210	7.43	719
26A2	4570	1870	6.41	789
30A1	4570	2360	8.55	772
28A2	4880	2030	7.43	835
32A	4880	2520	9.75	822
30A2	5180	2180	8.55	882
34A	5180	2690	11.06	872
31A	5490	2210	9.01	949
35A1	5490	2720	11.71	922
33A	5790	2360	10.22	992
37A	5790	2880	13.01	975
35A2	6100	2530	11.52	1042
39A	6100	3050	14.59	1025

Corrugation Profile: 152 mm x 51 mm

Corrugation Radius (CR):28.58 mm

Wall Thickness		Area(A) (mm ² / mm)	Tangent		Moment of Inertia(I) (mm ⁴ / mm)	Section Modulus(S) (mm ³ / mm)	Radius of Gyration(r) (mm)
Specified (mm)	Design(T) (mm)		Length(TL) (mm)	Angle(Δ) (degrees)			
3.0	2.84	3.522	47.876	44.531	1057.25	39.42	17.326
4.0	3.89	4.828	46.748	44.899	1457.56	53.30	17.375
5.0	4.95	6.149	45.582	45.286	1867.12	66.98	17.425
6.0	6.00	7.461	44.396	45.686	2278.31	80.22	17.475
7.0	7.00	8.712	43.237	46.083	2675.11	92.56	17.523

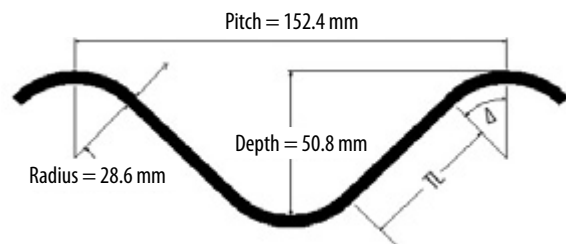

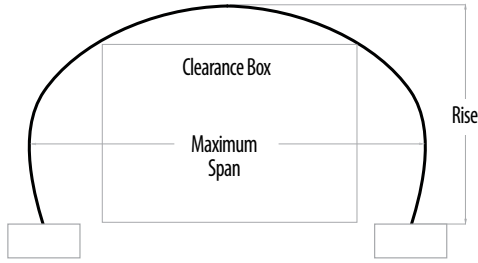

HIGH PROFILE ARCH

High Profile Arches are ideal for projects needing larger spans and clearance boxes, like highway grade separations.

No.	Max. Span (mm)	Bottom Span (mm)	Total Rise (mm)	End Area (m ²)	Min. Cover CL-Vehicle (mm)
23HA6-6	6300	5740	3680	20.34	1265
21HA5-4	6121	5944	2769	14.07	1181
25HA7-8	6960	6045	4445	26.41	1379
25HA5-6	6550	6050	3560	20.46	1388
26HA6-8	6985	6096	4267	25.48	1437
26HA5-6	6780	6270	3610	21.36	1442
27HA5-6	7010	6530	3660	22.28	1498
27HA7-8	7417	6553	4521	28.66	1491
29HA5-8	7468	6680	4191	26.67	1613
28HA5-6	7240	6760	3680	23.21	1562
30HA5-6	7670	7230	3740	25.09	1684
30HA6-9	7870	6920	4655	32.98	1663
29HA7-8	7849	7061	4623	30.94	1598
30HA5-7	7671	7087	4013	26.16	1672
31HA6-9	8100	7190	4650	34.17	1721
30HA7-8	8077	7315	4648	32.13	1644
31HA5-7	7899	7341	4039	27.19	1707
33HA6-10	8560	7500	5020	38.74	1834
31HA7-8	8306	7569	4699	33.32	1702
34HA5-9	8590	7750	4630	35.51	1905
33HA5-7	8357	7823	4140	29.29	1841
34HA5-8	8585	7899	4394	32.20	1896
34HA8-10	9169	8153	5512	43.21	1863
33HA8-8	8966	8255	5004	38.16	1814
36HA6-9	9220	8420	4920	40.28	2014
37HA8-12	9855	8509	6071	51.29	2036
36HA6-8	9906	8585	4699	36.94	2221
36HA8-10	9627	8636	5588	46.05	1978
37HA6-9	9450	8670	4970	41.53	2064
37HA7-10	9652	8687	5410	44.72	2049
38HA6-10	9680	8740	5260	45.25	2120
38HA8-12	10084	8763	6121	52.86	2094
37HA6-8	9449	8839	4750	38.12	2053
39HA6-10	9910	8990	5280	46.58	2186
39HA8-12	10312	9017	6172	54.47	2144
41HA7-12	10541	9322	6045	54.67	2270
41HA8-13	10744	9322	6477	59.75	2260
41HA6-10	10363	9500	5385	47.53	2300
41HA6-12	10360	9140	5830	54.58	2301
42HA7-12	10770	9576	6096	56.23	2330
41HA11-13	11354	9906	7137	69.21	2251
41HA11-12	11350	10130	6910	69.09	2260
42HA11-13	11582	10185	7163	71.06	2307
42HA6-10	10570	9730	5440	50.65	2361
42HA6-12	10590	9390	5870	56.07	2361
42HA11-12	11580	10390	6930	70.85	2319

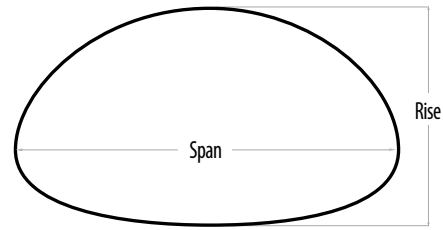

PIPE ARCH

Pipe Arches are ideal for smaller bridges and underpasses with limited overhead clearance. Their unique shape provides hydraulic advantages at low flow rates for culverts and sewers.

No.	Span (mm)	Rise (mm)	End Area (m ²)	Min. Cover CL-Vehicle (mm)
11PA6-5	1854	1397	2.04	300
12PA6-5	1930	1448	2.23	300
12PA6-6	2057	1499	2.42	300
9PA10-5	2060	1520	2.49	300
13PA6-6	2134	1549	2.60	300
14PA6-6	2210	1600	2.88	300
11PA10-5	2240	1630	2.90	300
14PA6-7	2337	1651	3.07	300
15PA6-7	2413	1702	3.25	308
12PA10-6	2440	1750	3.36	311
14PA10-6	2590	1880	3.87	330
16PA6-8	2616	1803	3.72	333
16PA10-6	2690	2080	4.49	343
17PA6-9	2845	1905	4.27	362
15PA10-9	3100	1980	4.83	641
19PA6-11A	3267	2121	5.39	600
15PA10-11	3400	2010	5.28	889
22PA6-12A	3554	2430	6.78	618
18PA10-12	3730	2290	6.61	722
23PA10-11	3890	2690	8.29	674
24PA10-12	4039	2845	9.01	711
25PA10-12	4115	2896	9.48	717
26PA10-13	4318	2997	10.13	754
25PA10-13	4267	2946	9.75	754
24PA10-14	4370	2870	9.76	796
27PA10-13A	4398	3070	10.74	762
27PA10-14	4547	3099	10.96	796
27PA10-15	4720	3070	11.38	855
28PA10-15	4750	3200	11.80	838
29PA10-16	4953	3302	12.73	878
30PA10-16C	5024	3379	13.36	884
30PA10-17	5182	3404	13.56	924
31PA10-17A	5232	3486	14.31	923
32PA10-18C	5438	3597	15.29	964
33PA10-18A	5475	3705	15.92	959
34PA10-20C	5858	3808	17.32	1047
37PA10-21C	6149	4110	19.73	1077
31PA22-21	7040	4060	22.48	1422
33PA22-24	7620	4240	25.27	1577

**ALL DIMENSIONS ARE TO INSIDE CREST OF STEEL
MINIMUM COVER IS FROM NEUTRAL AXIS OF STEEL**

CL Vehicle Minimum Cover
CHBDC for Span > 3000 mm
ASTM A796 (AISI) for Span < 3000 mm

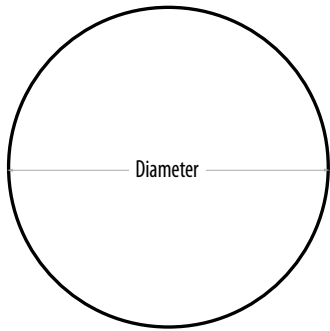

ROUND

Rounds are used primarily for larger culverts, sewers and sub-drains, but are also appropriate for storage bins, tunnels and utilidors.

No.	Span (mm)	Total Rise (mm)	End Area (m ²)	Min. Cover CL-Vehicle (mm)
20R	1500	1500	1.77	300
22R	1660	1660	2.16	300
24R	1810	1810	2.57	300
26R	1970	1970	3.05	300
28R	2120	2120	3.53	300
30R	2280	2280	4.08	300
32R	2430	2430	4.64	310
34R	2590	2590	5.27	330
36R	2740	2740	5.89	349
40R	3050	3050	7.30	600
44R	3360	3360	8.86	600
48R	3670	3670	10.57	620
52R	3990	3990	12.50	674
56R	4300	4300	14.49	725
60R	4610	4610	16.66	777
64R	4920	4920	18.99	829
68R	5230	5230	21.46	880
72R	5540	5540	24.08	932
76R	5850	5850	26.86	984
80R	6160	6160	29.79	1035
84R	6470	6470	32.87	1087
88R	6780	6780	36.10	1139
92R	7090	7090	39.48	1190
96R	7400	7400	43.01	1242
100R	7710	7710	46.70	1294
104R	8020	8020	50.53	1345

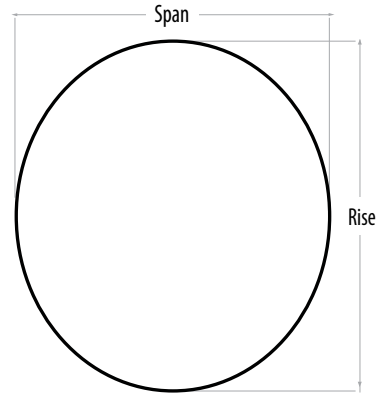

VERTICAL ELLIPSE

Vertical Ellipses are recommended for single lane road or rail underpasses and service tunnels.

No.	Max. Span (mm)	Total Rise (mm)	End Area (m ²)	Min. Cover CL-Vehicle (mm)
10VE6	2310	2570	4.63	300
11VE6	2460	2740	5.23	314
9VE9	2620	2900	5.89	334
14VE6	2920	3230	7.29	371
16VE6	3200	3560	8.86	600
18VE6	3580	3890	10.87	600
17VE9	3810	4220	12.43	612
19VE9	4140	4570	14.43	666
12VE18	4340	4830	16.58	697
14VE18	4650	5160	18.88	746
14VE20	4950	5460	21.35	793
18VE18	5260	5820	23.97	842
18VE20	5540	6120	26.73	886
19VE21	5840	6450	29.65	934
21VE21	6120	6780	32.72	979

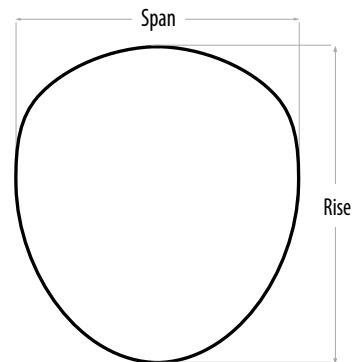

PEAR SHAPED UNDERPASS

Pear Shapes are generally used for railway tunnels and smaller underpasses.

No.	Max. Span (mm)	Bottom Rise (mm)	Total Rise (mm)	End Area (m ²)
25PS-5-24-15	7210	4550	7820	44.69
27PS-5-25-18	7570	5100	8430	50.54
30PS-6-26-16	8360	5510	8230	53.70
28PS-5-30-12	8100	5460	8610	54.91
27PS-8-22-25	8560	5130	8480	57.97
27PS-5-24-18	7320	4880	8530	48.84

ALL DIMENSIONS ARE TO INSIDE CREST OF STEEL
MINIMUM COVER IS FROM NEUTRAL AXIS OF STEEL

CL Vehicle Minimum Cover
CHBDC for Span > 3000 mm
ASTM A796 (AISI) for Span < 3000 mm

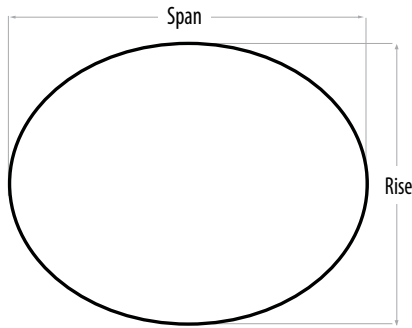

HORIZONTAL ELLIPSE

Horizontal Ellipses are well suited for underpasses and stream crossings.

**ALL DIMENSIONS ARE TO INSIDE CREST OF STEEL
MINIMUM COVER IS FROM NEUTRAL AXIS OF STEEL**

CL Vehicle Minimum Cover
CHBDC for Span > 3000 mm
ASTM A796 (AISI) for Span < 3000 mm

No.	Span (mm)	Rise (mm)	End Area (m ²)	Min. Cover CL-Vehicle (mm)
15HE15	1570	1430	1.77	300
10HE10	1630	1350	1.74	300
18HE15	1800	1510	2.14	300
12HE12	2130	1420	2.41	300
18HE10	2540	1630	3.24	324
18HE12	2790	1630	3.57	355
22HE10	2900	1930	4.36	369
24HE12	3200	2260	5.64	795
30HE10	3680	2440	6.85	898
28HE12	3760	2260	6.62	1084
42HE27	3990	3020	9.48	764
45HE27	4220	3100	10.22	820
30HE18	4420	2790	9.78	983
51HE27	4660	3260	11.89	929
51HE30	4760	3480	12.91	928
36HE18	4826	3429	12.86	961
51HE33	4860	3690	14.03	930
36HE22	5283	3531	14.59	1029
60HE27	5340	3510	14.49	1105
63HE27	5560	3590	15.42	1162
36HE28	5715	3988	18.08	1138
66HE27	5790	3670	16.44	1212
66HE30	5890	3890	17.74	1208
46HE20	6120	3960	18.77	1269
48HE18	6230	3840	18.40	1337
72HE30	6340	4050	19.79	1322
50HE18	6460	3910	19.42	1394
52HE18	6680	3990	20.49	1460
54HE20	7010	4290	23.15	1501

No.	Span (mm)	Rise (mm)	End Area (m ²)	Min. Cover CL-Vehicle (mm)
81HE42	7420	5160	29.83	1483
58HE20	7470	4470	25.49	1615
90HE30	7670	4550	26.76	1673
58HE30	7950	5540	34.25	1591
93HE33	8000	4830	29.76	1716
96HE33	8230	4930	31.26	1772
60HE32	8280	5820	37.59	1610
93HE48	8510	5920	39.24	1701
66HE24	8560	5210	34.28	1834
99HE48	8790	5310	35.86	1885
66HE32	8970	6070	42.23	1821
102HE48	9170	6170	44.07	1863
72HE24	9220	5460	38.55	2011
105HE51	9500	6450	47.64	1922
108HE54	9830	6760	51.80	1976
111HE54	10060	6830	53.32	2035
78HE28	10110	6120	47.57	2165
114HE57	10390	7110	57.26	2093
123HE42	10540	6300	50.96	2272
82HE30	10640	6500	53.29	2271
117HE60	10690	7420	61.79	2139
117HE66	10900	7850	66.79	2141
84HE32	10970	6810	57.51	2332
82HE42	11250	7800	68.25	2297
123HE45	11330	6760	58.69	2445
84HE44	11580	8100	72.93	2318
84HE48	11790	8510	78.31	2315
129HE78	12190	9020	86.12	2362

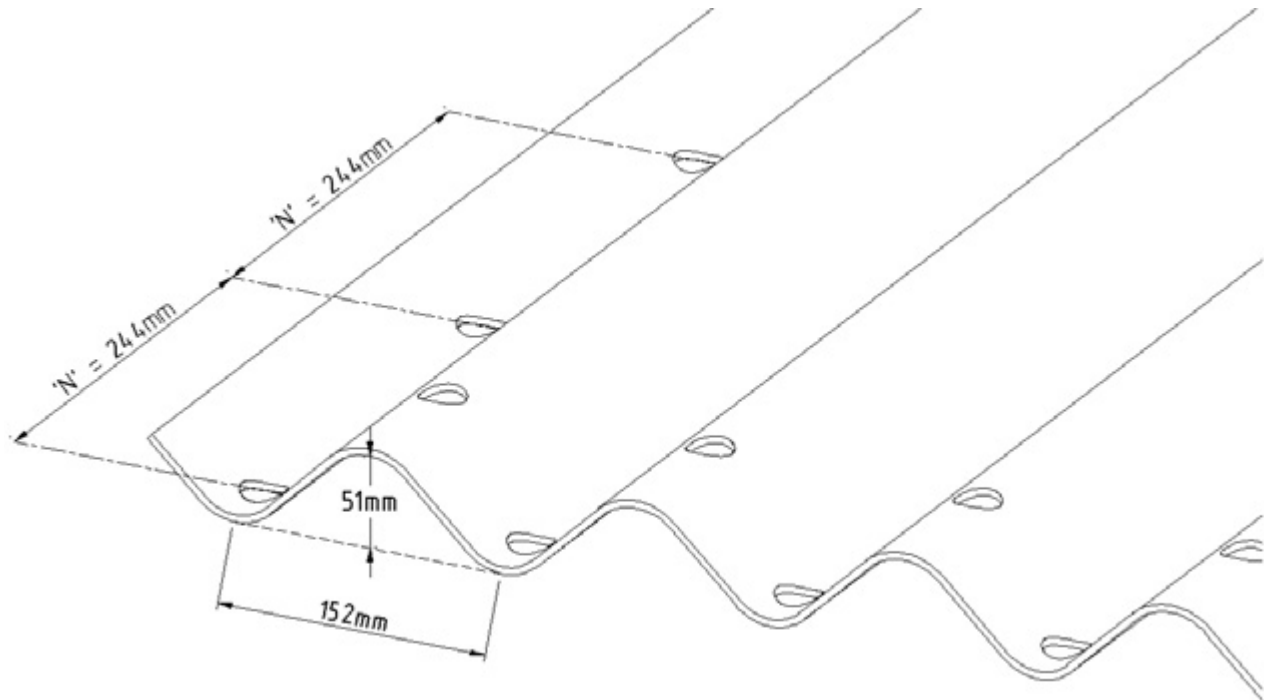

Bolt-A-Plate® structures distribute superimposed loads to the surrounding engineered backfill, so it is essential to use care during installation and backfilling to ensure proper performance. The following guidelines will help ensure a successful project.

Structural Design

The combination of structural steel and surrounding soil allows Bolt-A-Plate® to support extremely heavy loads. Standard designs are developed in accordance with the latest edition of the Canadian Highway Bridge Design Code. However, design assistance and recommendations can be specified to your project. Contact your local AIL Technical Sales Representative for assistance.

Site Investigation and Preparation

A thorough site investigation should be conducted before installing a Bolt-A-Plate® structure. If footings are to be used, the foundation will have to be capable of supporting vertical and horizontal loads developed by the structure. The aim is to design a structurally sound foundation that will allow the structure to develop full interaction between the soil and the steel. Site preparation should provide a solid base for the structure. It should be good-quality material, free from rocks, roots, debris and organic material. Pre-shaping of the site will allow for different configurations, speed up backfill operations and encourage increased backfill contact. AIL can offer technical assistance on foundation investigation and site preparation for varying site conditions.

Excavation

Trench excavation will vary, depending on the nature of the *in situ* material. It is necessary to provide an excavated area that ensures adequate distance from soils with questionable structural integrity. If the native soil is stable, excavate only the area that is required to provide minimum bedding, backfill envelope and enough room for compaction equipment to manoeuvre. For stream-crossing applications, local authorities will impose guidelines for construction activity.

Foundations

Bolt-A-Plate® structures are flexible and can accommodate some differential settlement without distress. It is important, nevertheless, to minimize differential settlement by removing and replacing poor foundation material. Pile foundations often create differential settlement issues. Preparation should be confined to minimum, but practical, widths and should result in a uniform base for the structure. A bedding of loose material will provide a slight cushion and the bedding may be flat or shaped, depending on the structure configuration and construction methods being used. It is essential that all corrugations be filled.

Assembly

A Bolt-A-Plate® structure typically arrives at the job site in nested bundles curved to the proper radius. (Some smaller structures can be delivered fully or partially assembled). Included are bolts and any other special hardware that may be required, as well as instructions and shop drawings listing all components. Assembly is easy, requiring relatively simple tools. Correct lapping, bolt-tightening and shape-monitoring are all important to achieve the correct design dimensions. Your AIL Technical Representative can provide information and assistance to those unfamiliar with structural plate assembly.

Backfill

Bolt-A-Plate® structures require a stable, engineered backfill to retain their shape and structural integrity. The quality of the backfill envelope depends on the choice of material, placement of backfill and compaction of the envelope. AIL will detail suitable backfill materials for the structures. A well-graded, free-draining, granular backfill is preferred. There is no substitute for an examination by a geotechnical engineer.

Inspection

Inspection should be performed on a full-time basis by qualified personnel. Backfill is placed in a balanced manner in 150 mm (6") to 200 mm (8") lifts for the entire backfill envelope. Compaction testing is required to ensure that backfill material is compacted to the required density, as shown on issued drawings. It is necessary to utilize well-maintained compaction equipment of the appropriate size and specification for the application and as referenced in the drawing notes.

End Finishes

Special attention must be paid to bevelled or skewed ends. Incomplete structural rings may need to be reinforced with steel or concrete (or tied back) to maintain structural integrity. Exercise caution when placing backfill around them to avoid distortion. Standard End Finishes are: Squared, Bevelled, Partially Bevelled and Skewed.



The CSPI Handbook of Steel Drainage & Highway Construction Products and the NCSPA handbook provide a new, detailed section on backfilling and the hydraulics of various steel structures. Your AIL Technical Sales Representative can provide you with a copy of this handbook.



Footing Options

Bolt-A-Plate® packages come with a variety of footing options to suit various sites:

- ▶ Precast or cast-in-place concrete footings – the most common footing type, in which a receiving angle is embedded in concrete.
- ▶ Steel footing pads – used as a time-saving alternative to concrete footings in sites with non-erodible stream beds. If the site permits, footings should be buried a minimum of 600 mm (24") below flow line. Note: When footing pads are buried, the published end area of Bolt-A-Plate® will be reduced.
- ▶ Full steel invert – for applications in erodible stream beds requiring a corrugated steel floor or invert. To prevent undermining of the invert, we recommend the use of an optional toewall for the upstream and downstream ends.

Concrete Footing

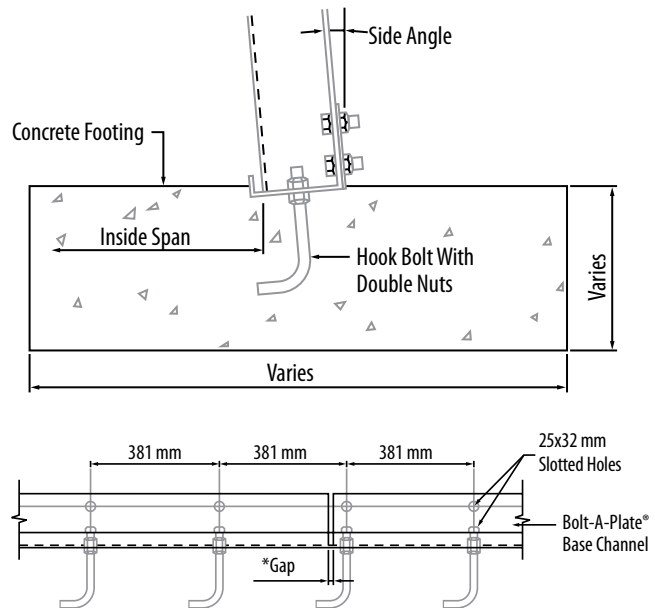

*Note: Space base channel so that 381 mm c/c spacing of slotted holes in long leg is maintained

Corrugated Steel Footing

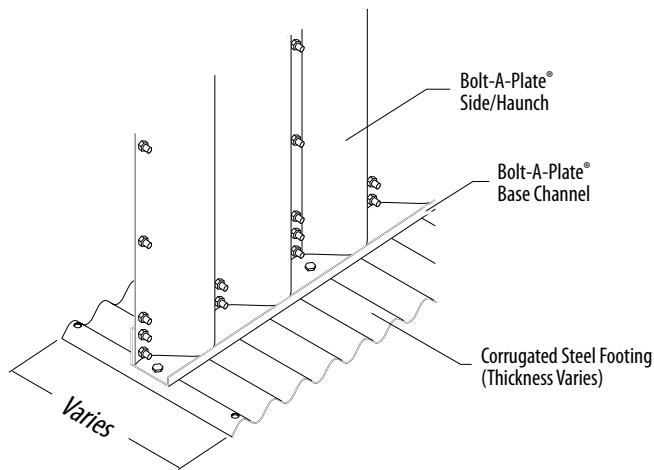

Headwall Options

In addition to enhancing their appearance, well-designed end treatments are essential to the structural and hydraulic performance of Bolt-A-Plate®.

- ▶ MSE Retaining Wall Systems with wire or concrete faces
- ▶ Concrete, cast-in-place or precast
- ▶ Bolt-A-Bin® retaining wall systems
- ▶ Sheet Pile walls
- ▶ Welded wire gabion baskets

Coating Options

Bolt-A-Plate's heavy galvanized coating is metallurgically bonded to the steel surface, providing extended service life. Bolt-A-Plate® is supplied with a standard 915 g/m² (3 oz/ft²) coating. A heavier 1220 g/m² (4 oz/ft²) coating is also available. Properly designed and installed, Bolt-A-Plate® structures will last over 100 years. Co-polymer coatings are also available to further extend service life.



Precast Panel Wall



Wire Wall



Steel Sheet Piling

Buried Bridges are easy to install with local crews.

AIL's Buried Metal Bridges ship and install quickly and economically, with minimal equipment and labour requirements. Our technical teams will guide you through the complete project.



Precast or cast-in-place concrete footings are set over the prepared site.



The first arch segment is completely assembled on the ground.



It is then lifted into place and bolted to the footings on either side. In most cases, a boom truck is sufficient for this.

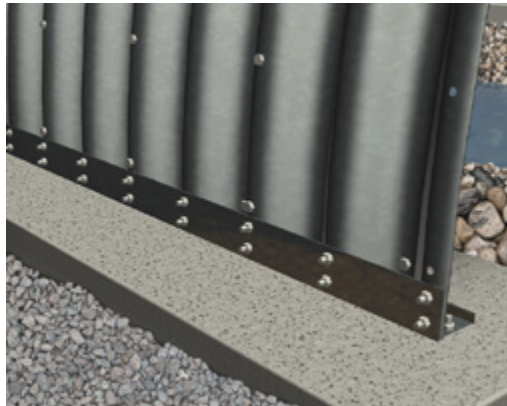

The segments bolt into base channels integrated into the concrete.

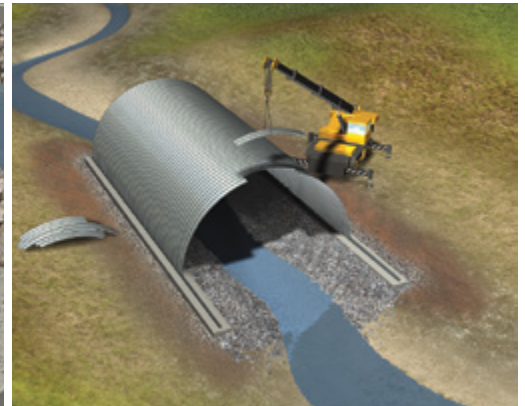

Plates then attach individually to make up other arch segments.



If specified, reinforcement ribs are then added.

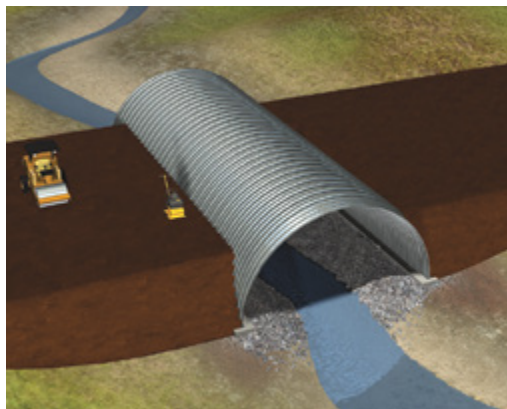

Layers of engineered backfill are added in sequential lifts.

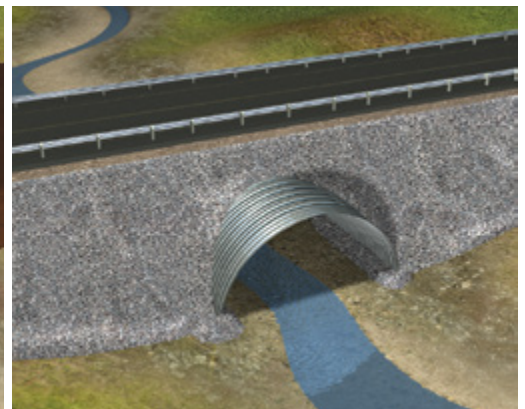

The road surface is then completed with safety barriers.

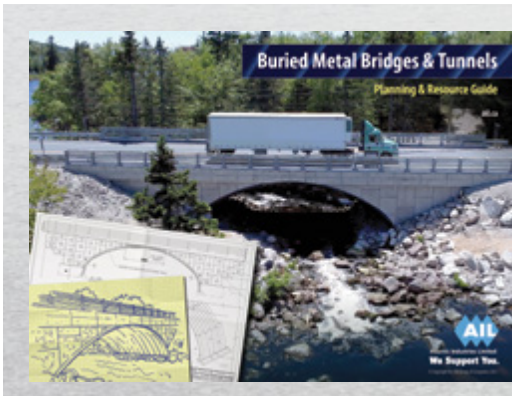

Download our Buried Metal Bridges & Tunnels Planning & Resource Guide

Discover how AIL's Buried Metal Bridges offer many advantages over concrete structures and bridges in this comprehensive guide with: benefits section, design ideas, aesthetic treatments, urban and northern sector/application galleries, complete product information and comparisons and installation details.



SCAN TO DOWNLOAD BROCHURE PDF

A structural plate for every application.

We specialize in Value Engineering cost-effective solutions for applications of all types. Our high-quality products, engineering excellence and innovative designs are key to delivering the best results for our clients.

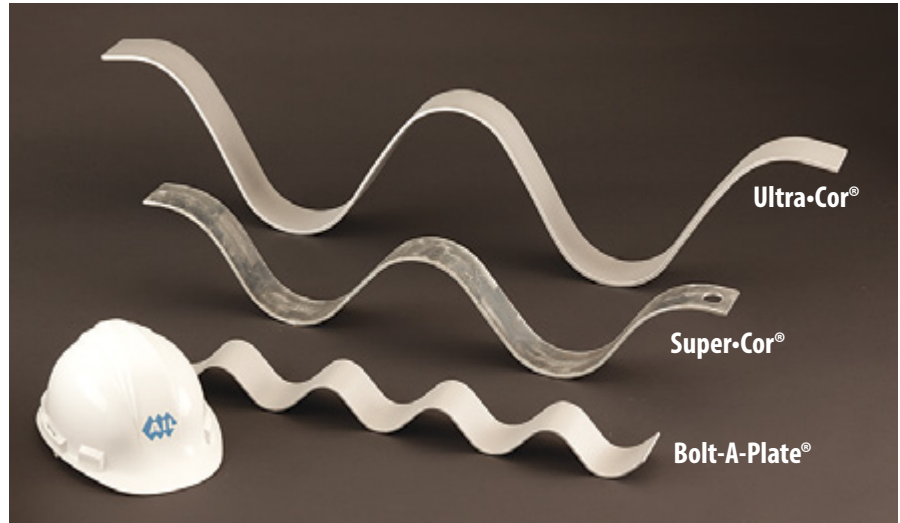

From the smallest structure to the world's largest Buried Metal Bridge — AIL has it covered.

BOLT-A-PLATE
Structural Steel Plate

1.5 m 10 m

With spans that can reach 10 m, Bolt-A-Plate® is recommended for smaller applications. Available in a wide range of shapes.

SUPER-COR
Structural Steel Plate

3 m 25 m

Deep-corrugated Super-Cor® is ideal for medium-sized applications, with spans able to reach 25 m. Available in a wide range of shapes.

ULTRA-COR
Structural Steel Plate

18 m 35+ m

The ultra-deep corrugations of Ultra-Cor® make it ideal for the largest and most extreme applications, with spans able to exceed 35 m. Available in a wide range of shapes.

FOR PROJECT ASSISTANCE THROUGHOUT CANADA, CALL 1-877-245-7473. OUTSIDE CANADA, CALL +1-778-335-7000.

The information and suggested applications in this brochure are accurate and correct to the best of our knowledge, and are intended for general information purposes only. These general guidelines are not intended to be relied upon as final specifications, and we do not guarantee specific results for any particular purpose. We strongly recommend consultation with an Atlantic Industries Limited Technical Sales Representative before making any design and purchasing decisions.



AIL products contain recycled content and are 100% recyclable.

ISO Certified

In keeping with AIL's ongoing commitment to high standards, our Plate Manufacturing Facility in Ayr, Ontario, and our Engineering Department in Cambridge, Ontario, have been certified to ISO 9001:2008.

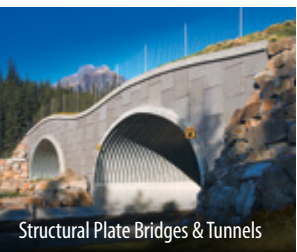

Structural Plate Bridges & Tunnels



Prefabricated Bridges

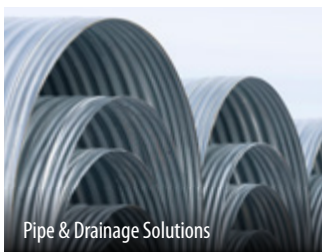

Pipe & Drainage Solutions

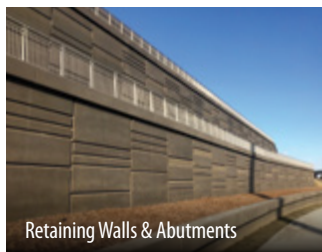

Retaining Walls & Abutments



Sound Barrier Walls

AIL OFFERS A COMPLETE RANGE OF BRIDGE AND INFRASTRUCTURE SOLUTIONS.



Atlantic Industries Limited

Corporate Office:

PO Box 6161, 32 York St.
Sackville, New Brunswick
Canada E4L 1G6
Phone: (506) 364-4600

Locations across Canada:

St. John's, NL • Deer Lake, NL • Dorchester, NB
Louisville, QC • Ottawa, ON • Toronto, ON • Ayr, ON
Cambridge, ON • Kenora, ON • Calgary, AB • Edmonton, AB
Westlock, AB • Armstrong, BC • Vancouver, BC



Atlantic Industries Limited is a member of
THE AIL GROUP OF COMPANIES



Atlantic Industries Limited



INTERNATIONAL



SOUND WALLS

